

Installation Guide

Photoelectric sensors with electromechanical relay output

Figure 1. Sensor shown with gasketed acrylic cover removed.

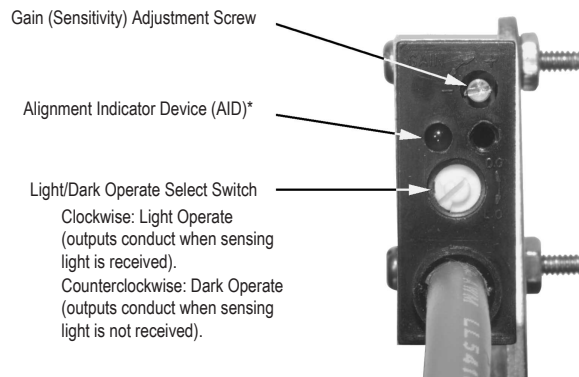

*U.S. Patent no. 4356393



WARNING:

- Do not use this device for personnel protection
- Using this device for personnel protection could result in serious injury or death.
- This device does not include the self-checking redundant circuitry necessary to allow its use in personnel safety applications. A device failure or malfunction can cause either an energized (on) or de-energized (off) output condition.

Models

Model ¹	Range	LED	Sensing Mode	
SMU31E	3 m (10 ft)	Infrared, 880 nm	Opposed Emitter	<p>OPPOSED</p>
SMU31R			Opposed Receiver	
SMU31EL			Opposed Emitter - Long Range	
SMU31RL	Opposed Receiver - Long Range			
SMU315LV	5 m (15 ft)	Visible Red, 650 nm	Non-Polarized Retroreflective	<p>RETRO</p>
SMU315LP	10 mm to 3 m (0.4 in to 10 ft)		Polarized Retroreflective	<p>POLAR RETRO</p>
SMU315D	380 mm (15 in)		Diffuse	<p>DIFFUSE</p>
SMU315W	130 mm (5 in)	Infrared, 880 nm	Divergent Diffuse	
SMU315CV	16 mm (0.65 in) 1.3 mm (0.05 in) ²	Visible Red, 650 nm	Convergent	<p>CONVERGENT</p>
SMU315CV2	43 mm (1.7 in) 3 mm (0.07 in) ²			

¹ Integral 2 m (6.5 ft) unterminated cable models are listed.

• To order the 9 m (30 ft) PVC cable model, add the suffix "W/30" to the cabled model number. For example, SMU31E W/30.

² Spot size (diameter of sensing beam) at focus.

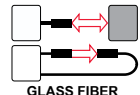

Model ¹	Range	LED	Sensing Mode	
SMU315F	Range varies depending on sensing mode and fiber optics used	Infrared , 880 nm	Glass Fiber Optic	 <p>GLASS FIBER</p>
SMU315FV				
SMU315FP		Visible Red, 650 nm	Plastic Fiber Optic	

Wiring Diagrams

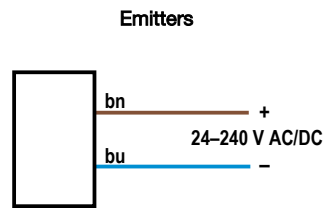
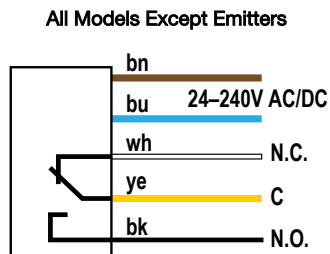

- Output type for all models (except emitters) is SPDT Electromechanical Relay
- Install transient suppressor (MOV) across contacts switching inductive loads
- Connection of DC power is without regard to polarity
- Maximum switching current is 3 amps - see Specifications

Installation and Alignment

MINI-BEAM sensors perform most reliably if they are properly aligned and securely mounted. For maximum mechanical stability, mount MINI-BEAM sensors through 18 mm diameter holes by their threaded barrel (where available), or use a mounting bracket. A complete selection of mounting brackets is available. Visit www.bannerengineering.com or contact Banner Engineering for information on mounting options.

1. Begin with line-of-sight positioning of the MINI-BEAM sensor to its emitter (opposed-mode sensing) or to its target (all other sensing modes).
 - When using a retroreflective sensor, the target is the retroreflector (or *retro target*).
 - For diffuse or convergent sensing modes, the target is the object to be detected.
2. Apply power to the sensor (and to the emitter, if using the opposed mode).
3. Advance the 15-turn Gain control to maximum (clockwise end of rotation), using a small flat-blade screwdriver.

The Gain control is clutched at both ends to avoid damage, and will free-wheel when either endpoint is reached.

If the MINI-BEAM sensor is receiving its light signal, then the red LED alignment indicator is ON and flashing at a rate proportional to the signal strength (faster = more signal).
4. Move the sensor (or move the retro target, if applicable) up-down-right-left (including angular rotation) to find the center of the movement zone within which the LED indicator remains ON.
5. Reduce the Gain setting by turning the Gain control.

Reducing the Gain setting reduces the size of the movement zone, and enables more precise alignment.
6. Repeat the alignment motions after each Gain reduction.
7. When optimum alignment is achieved, mount the sensor(s) (and the retro target, if applicable) solidly in that position.
8. Increase the Gain to maximum.
9. Test the sensor by placing the object to be detected in the sensing position, and then removing it.

The Alignment Indicator LED should turn ON when the sensing beam is established (Light condition), and turn OFF when the beam is broken (Dark condition).

¹ Integral 2 m (6.5 ft) unterminated cable models are listed.

- To order the 9 m (30 ft) PVC cable model, add the suffix "W/30" to the cabled model number. For example, SMU31E W/30.

Opposed Mode Alignment

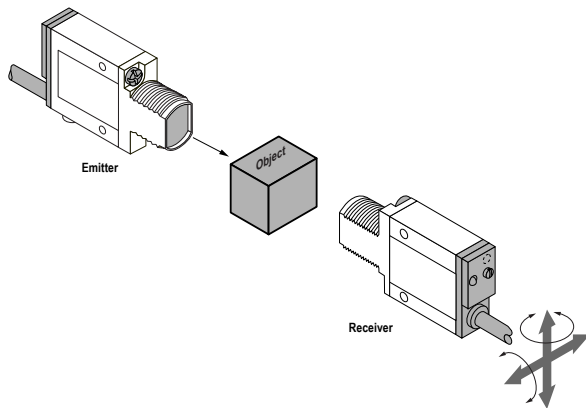

Flooding occurs when a portion of the sensing beam passes around the object to be sensed. *Burn-through* occurs when a portion of the emitter's light energy passes through a thin or translucent object, and is sensed by the receiver.

To correct either problem, do one or more of the following to reduce the light energy:

- Reduce the Gain adjustment on the receiver
- Add an aperture to one or both lenses (MINI-BEAM apertures, available from Banner, fit neatly inside the lens assembly)
- Intentionally misalign the emitter and receiver



Note:

- Light condition: sensor output is ON when there is no object in the beam
- Dark condition: sensor output is ON when there is an object in the beam

Retroreflective Mode Alignment

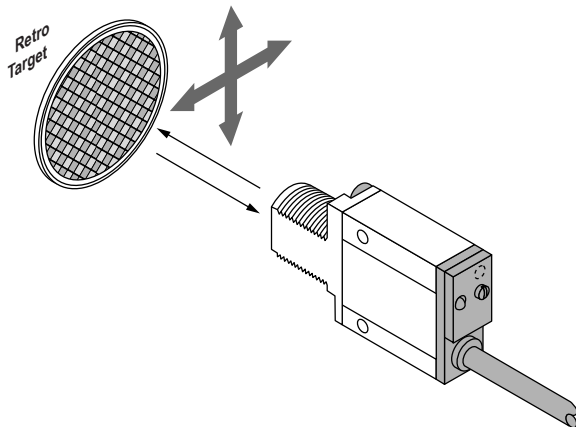

A highly reflective object may reflect enough light back to a retroreflective sensor to allow that object to slip through the beam, without being detected. This problem is called *proxing*, and the following methods may be used to correct it:

- Position the sensor and retro target so the beam will not strike a shiny surface perpendicular to the sensor lens
- Reduce the Gain adjustment
- Add a polarizing filter (for model SMU315LV).



Note:

- Light condition: sensor output is ON when there is no object in the beam
- Dark condition: sensor output is ON when there is an object in the beam

Diffuse Mode Alignment

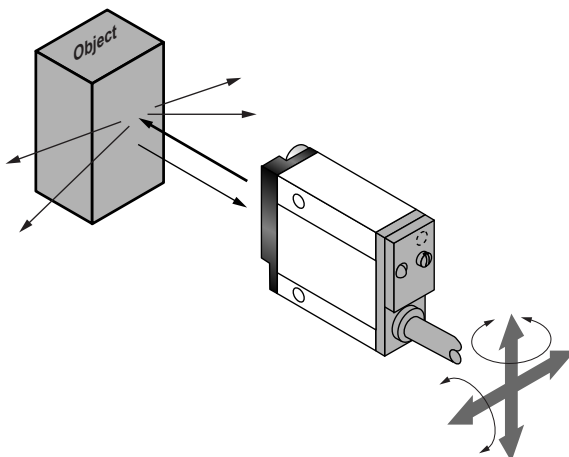

If the Alignment LED does not turn OFF when the object is removed from the beam, the sensor is probably detecting light reflected from some background object. To remedy this problem:

- Reduce the reflectivity of the background by painting the surface(s) flat-black, scuffing any shiny surface, or drilling a large hole, directly opposite the diffuse sensor
- Move the sensor closer to the object to be detected and reduce the Gain adjustment. Rule of thumb for diffuse sensing: The distance to the nearest background object should be at least three times the sensing distance



Note:

- Light condition: sensor output is ON when there is an object in the beam
- Dark condition: sensor output is ON when there is no object in the beam

Convergent Mode Alignment

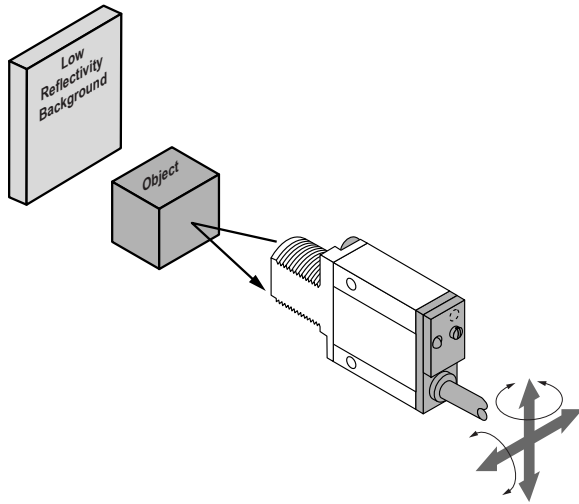

The sensing energy of a convergent mode sensor is concentrated at the specified focus point. Convergent mode sensors are less sensitive to background reflections, compared with diffuse mode sensors. However, if background reflections are a problem:

- Skew the sensor position at a 10° to 25° angle to eliminate direct reflections from shiny background surfaces
- Reduce the reflectivity of the background by painting the surface(s) flat-black, scuffing any shiny surface, or drilling a large hole, directly opposite the sensor
- Reduce the Gain adjustment

Note:

- Light condition: sensor output is ON when there is an object in the beam
- Dark condition: sensor output is ON when there is no object in the beam

Installing the Glass Fibers in MINI-BEAMS

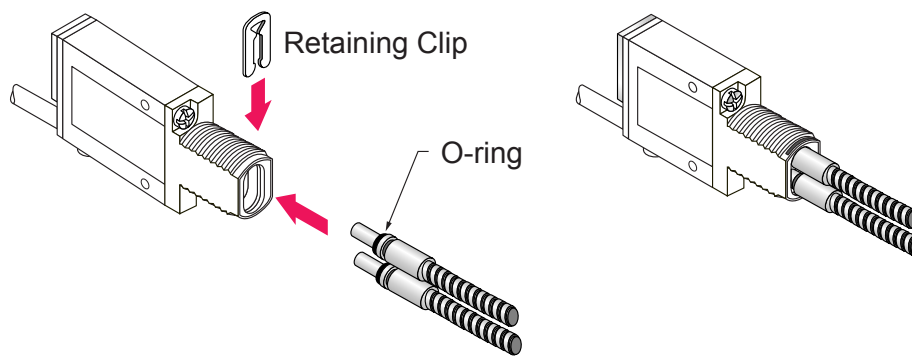

1. Install the O-ring (supplied with the fiber) on each fiber end, as shown in the drawing.
2. While pressing the fiber ends firmly into the ports on the sensor front, slide the U-shaped retaining clip (supplied with the sensor) into the slot in the sensor's barrel, until it snaps into place.

Installing Plastic Fibers on a MINI-BEAM

Follow these instructions to install plastic fibers into your sensor. MINI-BEAMS may have either a fiber gripper or a clamp screw. **MINI-BEAM** and **ECONO-BEAM** sensors for use with plastic fiber optic assemblies include sensors with the letters **FP** in their model number.

Figure 2. MINI-BEAM with fiber grippers

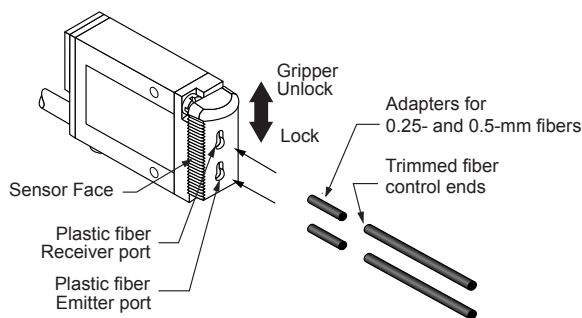
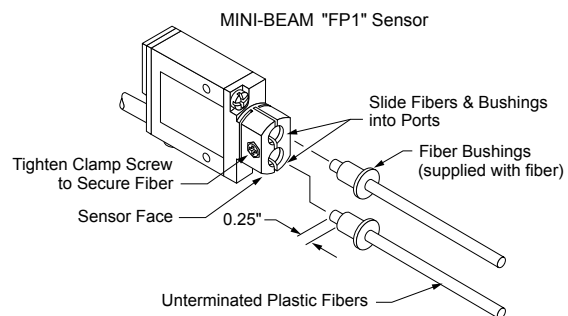

Figure 3. MINI-BEAM with clamp screws



1. Prepare the sensor ends of the fibers (see [Cut the Plastic Fiber](#) on p. 5).
2. Prepare the sensor for the fibers.
 - For models with a fiber gripper: Unlock the fiber gripper as shown in the figure and apply the appropriate fiber adaptors to the fiber, if needed.

- For models with a clamp screw: Loosen the clamp screw on the sensor face.
3. Insert the plastic fibers.
 - For models with a fiber gripper: Gently insert the prepared fiber ends into the ports as far as they will go.
 - For models with a clamp screw: Align the fiber ends flush with the ends of the bushings as shown. Hold the bushings to the fibers and slide both into the sensor ports. Push the fiber an additional 1 inch through the bushing.
 4. Lock in the fibers.
 - For models with a fiber gripper: Slide the fiber gripper back to lock, as shown in the figure.
 - For models with a clamp screw: Tighten the clamp screw to secure the fibers.

Cut the Plastic Fiber

An unterminated plastic fiber is designed to be cut by the customer to the length required for the application. To facilitate cutting, a Banner model PFC-4 cutting device is supplied with this fiber.

1. Locate the non-terminated end, and determine the length of fiber required for the application.
2. Lift the top of the cutter to open the cutting ports.
3. Insert the non-terminated end through one of the four large cutting ports on the PFC-4 cutter so that the excess fiber protrudes from the back of the cutter.
4. Double-check the fiber length, and close the cutter until the fiber is cut.
5. Gently wipe the cut ends of the fiber with a clean, dry cloth to remove any contamination.



Note: Do not use solvents or abrasives on any exposed optical fiber. Do not use a cutting port more than once. The blade may tend to dull after one cut.

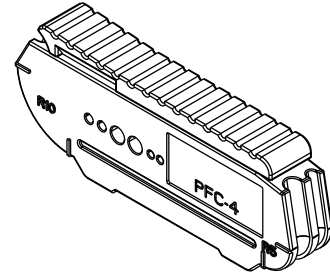

Specifications

Supply Voltage and Current

24 V AC to 240 V AC, 50/60 Hz or
24 V DC to 240 V DC (1.5 watts or 2.5 VA maximum)

Supply Protection Circuitry

Protected against transient voltages. DC wiring is without regard to polarity.

Output Configuration

SPDT (Single-Pole, Double Throw) (form C) electromechanical relay, ON/OFF output

Output Rating

Maximum switching power (resistive load): 90 watts, 250 VA
Maximum switching voltage (resistive load): 250 V AC or 30 V DC
Maximum switching current (resistive load): 3 A
Minimum voltage and current: 5 V DC, 10 mA
Mechanical life: 20,000,000 operations
Electrical life at full resistive load: 100,000 operations

Output Protection Circuitry

Protected against false pulse on power up

Output Response Time

Closure time: 20 milliseconds maximum
Release time: 20 milliseconds maximum
Maximum switching speed: 25 operations per second

Repeatability

All sensing modes: 1 millisecond

Adjustments

Light/Dark Operate select switch
15-turn slotted brass screw Gain (sensitivity) adjustment potentiometer
Located on rear panel, protected by gasketed, clear acrylic cover. See Installation and Alignment.

Indicators

Patented Alignment Indicator Device system (AID™) lights a rear-panel-mounted LED indicator whenever the sensor sees a "light" condition. Its pulse rate is proportional to the light signal strength (the stronger the signal, the faster the pulse rate).

Construction

Reinforced thermoplastic polyester housing, totally encapsulated, o-ring seal, acrylic lenses, and stainless steel screws

Environmental Rating

NEMA 1, NEMA 2, NEMA 3, NEMA 3S, NEMA 4, NEMA 4X, NEMA 63, NEMA 12, and NEMA 13
IEC IP67

Connections

5-conductor (2-conductor for emitters) 2 m (6.5 ft) unterminated PVC-jacketed cable or 9 m (30 ft) unterminated PVC-jacketed cable

Operating Conditions

Temperature: -20 °C to +55 °C (-4 °F to +131°F)
90% at +50 °C maximum relative humidity (non-condensing)

Application Note

Install transient suppressor (MOV) across contacts switching inductive loads